



IEC/TC or SC: TC 57	Project number IEC 61850-9-2 Ed. 2.0	
Title of TC/SC: POWER SYSTEMS MANAGEMENT AND ASSOCIATED INFORMATION EXCHANGE	Date of circulation 2005-11-25	Closing date for comments 2006-03-03
	Also of interest to the following committees	
Supersedes document 57/799/MCR		
Functions concerned: <input type="checkbox"/> Safety <input type="checkbox"/> EMC <input type="checkbox"/> Environment <input type="checkbox"/> Quality assurance		
Secretary: Germany, Dr. Andreas Huber	THIS DOCUMENT IS STILL UNDER STUDY AND SUBJECT TO CHANGE. IT SHOULD NOT BE USED FOR REFERENCE PURPOSES. RECIPIENTS OF THIS DOCUMENT ARE INVITED TO SUBMIT, WITH THEIR COMMENTS, NOTIFICATION OF ANY RELEVANT PATENT RIGHTS OF WHICH THEY ARE AWARE AND TO PROVIDE SUPPORTING DOCUMENTATION.	

Title:
Communication networks and systems in substations – Part 9-2: Specific Communication Service Mapping (SCSM) – Sampled values over ISO/IEC 8802-3

(Titre) :

Introductory note

Copyright © 2005 International Electrotechnical Commission, IEC. All rights reserved. It is permitted to download this electronic file, to make a copy and to print out the content for the sole purpose of preparing National Committee positions. You may not copy or "mirror" the file or printed version of the document, or any part of it, for any other purpose without permission in writing from IEC.



CONTENTS

FOREWORD	4
INTRODUCTION	6
1 Scope	7
2 Normative references	7
3 Terms and definitions	9
4 Abbreviations	9
5 Communication stack	10
5.1 Overview of the protocol usage.....	10
5.2 Client/server services and communication profiles	11
5.2.1 Client/server services	11
5.2.2 A-Profile	12
5.2.3 TCP/IP T-Profile	12
5.3 SV service and communication profile	13
5.3.1 SV mapping overview	13
5.3.2 A-Profile	13
5.3.3 T-Profile	13
5.4 Restrictions	15
6 Mapping of IEC 61850-7-2 and IEC 61850-7-3 Data Attributes	16
7 Mapping of IEC 61850-7-2 classes and services	16
7.1 Classes of SV data sets	16
7.2 Definition of SV data sets	16
8 Mapping of the model for the transmission of sampled values	16
8.1 Overview	16
8.2 Mapping of the multicast sampled value control block class and services	16
8.2.1 Multicast sampled value control block definition	16
8.2.2 MSV Services.....	19
8.3 Mapping of the unicast sampled value control block class and services.....	19
8.3.1 Unicast sampled value control block definition.....	19
8.3.2 USV Services	20
8.4 Mapping of the update of the sampled value buffer	21
8.5 Additional definitions for the transmission of sampled values	21
8.6 Definitions for basic data types	23
9 Conformance.....	23
9.1 Notation	23
9.2 PICS.....	23
9.2.1 Profile conformance	23
9.2.2 SV Services	24
10 Substation Configuration language (SCL)	25
Annex A (informative) ISO/IEC 8802-3 frame format and ASN.1 basic encoding rules.....	26
A.1 ISO/IEC 8802-3 frame format	26
A.2 ASN.1 Basic Encoding Rules (BER).....	27
A.3 Example for an ASN.1 coded APDU frame structure	28
Annex B (informative) Process bus architectures.....	29
Annex C (informative) Multicast address selection.....	31

Figure 1 – OSI reference model and profiles	10
Figure 2 - Structure of the tag header	14
Figure 3 – Concatenation of several ASDU's into one frame	21
Figure A.2 - Basic encoding rules format.....	27
Figure A.3 - Format of the tag octets.....	27
Figure A.4 - Example for an ASN.1 coded APDU frame structure	28
Figure B.1 - Alternative process bus architectures.....	29
Table 1 – Service requiring client/server communication profile.....	11
Table 2 – Service and protocols for client/server communication A-Profile	12
Table 3 – Service and Protocols for Peer TCP/IP T-Profile	12
Table 4 – Service requiring SV communication profile.....	13
Table 5 – Service and protocols for SV communication A-Profile.....	13
Table 6 – SV T-Profile	13
Table 7 – Default Virtual LAN IDs and priorities	14
Table 8 – Assigned Ethertype values	15
Table 9 – MMS TypeDescription definition for MSVCB MMS structure	17
Table 10 - DstAddress structure	18
Table 11 – Mapping of multicast sampled value services.....	19
Table 12 – MMS TypeDescription definition for USVCB MMS Structure	19
Table 13 – Mapping of unicast sampled value services	20
Table 14 – Encoding for the transmission of the sampled value buffer	22
Table 15 – Encoding for the basic data types	23
Table 16 – PICS for A-Profile support	24
Table 17 – PICS for T-Profile support	24
Table 18 – SV conformance statement	24
Table 19 – Definitions for SV SCL	25
Table C.1 – Recommended multicast addressing example	31

INTERNATIONAL ELECTROTECHNICAL COMMISSION

COMMUNICATION NETWORKS AND SYSTEMS IN SUBSTATIONS –**Part 9-2: Specific Communication Service Mapping (SCSM) –
Sampled values over ISO/IEC 8802-3**

FOREWORD

- 1) The International Electrotechnical Commission (IEC) is a worldwide organization for standardization comprising all national electrotechnical committees (IEC National Committees). The object of IEC is to promote international co-operation on all questions concerning standardization in the electrical and electronic fields. To this end and in addition to other activities, IEC publishes International Standards, Technical Specifications, Technical Reports, Publicly Available Specifications (PAS) and Guides (hereafter referred to as "IEC Publication(s)"). Their preparation is entrusted to technical committees; any IEC National Committee interested in the subject dealt with may participate in this preparatory work. International, governmental and non-governmental organizations liaising with the IEC also participate in this preparation. IEC collaborates closely with the International Organization for Standardization (ISO) in accordance with conditions determined by agreement between the two organizations.
- 2) The formal decisions or agreements of IEC on technical matters express, as nearly as possible, an international consensus of opinion on the relevant subjects since each technical committee has representation from all interested IEC National Committees.
- 3) IEC Publications have the form of recommendations for international use and are accepted by IEC National Committees in that sense. While all reasonable efforts are made to ensure that the technical content of IEC Publications is accurate, IEC cannot be held responsible for the way in which they are used or for any misinterpretation by any end user.
- 4) In order to promote international uniformity, IEC National Committees undertake to apply IEC Publications transparently to the maximum extent possible in their national and regional publications. Any divergence between any IEC Publication and the corresponding national or regional publication shall be clearly indicated in the latter.
- 5) IEC provides no marking procedure to indicate its approval and cannot be rendered responsible for any equipment declared to be in conformity with an IEC Publication.
- 6) All users should ensure that they have the latest edition of this publication.
- 7) No liability shall attach to IEC or its directors, employees, servants or agents including individual experts and members of its technical committees and IEC National Committees for any personal injury, property damage or other damage of any nature whatsoever, whether direct or indirect, or for costs (including legal fees) and expenses arising out of the publication, use of, or reliance upon, this IEC Publication or any other IEC Publications.
- 8) Attention is drawn to the Normative references cited in this publication. Use of the referenced publications is indispensable for the correct application of this publication.
- 9) Attention is drawn to the possibility that some of the elements of this IEC Publication may be the subject of patent rights. IEC shall not be held responsible for identifying any or all such patent rights.

International Standard IEC 61850-9-2 has been prepared by IEC technical committee 57: Power systems management and associated information exchange.

The text of this standard is based on the following documents:

FDIS	Report on voting
57/690/FDIS	57/709/RVD

Full information on the voting for the approval of this standard can be found in the report on voting indicated in the above table.

This publication has been drafted in accordance with the ISO/IEC Directives, Part 2.

IEC 61850 consists of the following parts, under the general title *Communication networks and systems in substations*:

- Part 1: Introduction and overview
- Part 2: Glossary
- Part 3: General requirements
- Part 4: System and project management
- Part 5: Communication requirements for functions and device models
- Part 6: Configuration description language for communication in electrical substations related to IEDs
- Part 7-1: Basic communication structure for substation and feeder equipment – Principles and models
- Part 7-2: Basic communication structure for substation and feeder equipment – Abstract communication service interface (ACSI)
- Part 7-3: Basic communication structure for substation and feeder equipment – Common data classes
- Part 7-4: Basic communication structure for substation and feeder equipment – Compatible logical node classes and data classes
- Part 8-1: Specific Communication Service Mapping (SCSM) – Mappings to MMS (ISO 9506-1 and ISO 9506-2) and to ISO/IEC 8802-3
- Part 9-1: Specific Communication Service Mapping (SCSM) – Sampled values over serial unidirectional multidrop point to point link
- Part 9-2: Specific Communication Service Mapping (SCSM) – Sampled values over ISO/IEC 8802-3
- Part 10: Conformance testing

INTRODUCTION

This part of IEC 61850 defines the SCSM for sampled values over ISO/IEC 8802-3. The intent of this SCSM definition is to supplement IEC 61850-9-1 to include the complete mapping of the sampled value model.

This part of IEC 61850 applies to electronic current and voltage transformers (ECT and EVT having a digital output), merging units, and intelligent electronic devices for example protection units, bay controllers and meters.

Process bus communication structures can be arranged in different ways as described in Annex B and IEC 61850-1. In addition to the transmission of sampled value data sets, which are directly connected to ISO/IEC 8802-3, a selection of IEC 61850-8-1 services are necessary to support the access to the SV control block. References to the relevant IEC 61850-8-1 services are provided in this SCSM. For less complex devices (for example merging units) the sampled value control block can be pre-configured, in which case there is no need to implement IEC 61850-8-1 services based on the MMS-Stack.

This document defines the mapping of sampled value class model (IEC 61850-7-2) to ISO/IEC 8802-3. This SCSM, in combination with IEC 61850-7 and IEC 61850-6, allows interoperability between devices from different manufacturers.

This standard does not specify individual implementations or products, nor does it constrain the implementation of entities and interfaces within a computer system. This standard specifies the externally visible functionality of implementations together with conformance requirements for such functionalities.

This second edition is solving technical issues that have been identified while implementing IEC 61850.

Reading Guide

- This document is an extended mapping specification of IEC 61850-9-1 and IEC 61850-8-1 to cover sampled value transmission over ISO/IEC 8802-3.
- This document can best be understood if the reader is thoroughly familiar with IEC 61850-7-1, IEC 61850-7-2, IEC 61850-7-3 and IEC 61850-7-4.
- The ACSI services defined in IEC 61850-7-2 are not explained in this part of the standard.

COMMUNICATION NETWORKS AND SYSTEMS IN SUBSTATIONS –

Part 9-2: Specific Communication Service Mapping (SCSM) – Sampled values over ISO/IEC 8802-3

1 Scope

This part of IEC 61850 defines the Specific Communication Service Mapping (SCSM) for the transmission of sampled values according to the abstract specification in IEC 61850-7-2. The mapping is that of the abstract model on a mixed stack using direct access to an ISO/IEC 8802-3 link for the transmission of the samples in combination with IEC 61850-8-1.

Each SCSM consists of three parts:

- a specification of the communication stack being used,
- the mapping of the abstract specifications of IEC 61850-7 on the real elements of the stack being used, and
- the implementation specification of functionality, that is not covered by the stack being used.

2 Normative references

The following referenced documents are indispensable for the application of this document. For dated references, only the edition cited applies. For undated references, the latest edition of the referenced document (including any amendments) applies.

IEC 60874-10-1, *Connectors for optical fibres and cables – Part 10-1: Detail specification for fibre optic connector type BFOC/2,5 terminated to multimode fibre type A1*

IEC 60874-10-2, *Connectors for optical fibres and cables – Part 10-2: Detail specification for fibre optic connector type BFOC/2,5 terminated to single-mode fibre type B1*

IEC 60874-10-3, *Connectors for optical fibres and cables – Part 10-3: Detail specification for fibre optic adaptor type BFOC/2,5 for single and multimode fibre*

IEC 61850-7-1, *Communication networks and systems in substations – Part 7-1: Basic communication structure for substation and feeder equipment – Part 7-1: Principles and models*

IEC 61850-7-2, *Communication networks and systems in substations – Part 7-2: Basic communication structure for substation and feeder equipment – Abstract communication service interface (ACSI)*

IEC 61850-7-3, *Communication networks and systems in substations – Part 7-3: Basic communication structure for substation and feeder equipment – Common data classes*

IEC 61850-7-4, *Communication networks and systems in substations – Part 7-4: Basic communication structure for substation and feeder equipment – Compatible logical node classes and data classes*

IEC 61850-8-1, *Communication networks and systems in substations – Part 8-1: Specific Communication Service Mapping (SCSM) – Mappings to MMS (ISO 9506-1 and ISO 9506-2) and to ISO/IEC 8802-3*

IEC 61850-9-1, *Communication networks and systems in substations – Part 9-1: Specific Communication Service Mapping (SCSM) – Sampled values over serial unidirectional multidrop point to point link*

ISO/IEC 7498-1:1994, *Information technology – Open Systems Interconnection – Basic Reference Model: The Basic Model*

ISO/IEC 8326:1996, *Information processing systems – Open Systems Interconnection – Session service definition*

ISO/IEC 8327-1:1997, *Information technology – Open Systems Interconnection – Connection-oriented session protocols: Protocol specification*

ISO/IEC 8649:1996, *Information technology – Open Systems Interconnection – Service definition for the Associated Control Service Element*

ISO/IEC 8650-1:1996, *Information technology – Open Systems Interconnection – Connection-oriented protocol for the Association Control Service Element: Protocol specification*

ISO/IEC 8802-3:2001, *Information technology – Telecommunications and information exchange between systems – Local and metropolitan area networks – Specific requirements – Part 3: Carrier sense multiple access with collision detection (CSMA/CD) access method and physical layer specifications*

ISO/IEC 8822:1994, *Information technology – Open Systems Interconnection – Presentation service definition*

ISO/IEC 8823-1:1994, *Information technology – Open Systems Interconnection – Connection-oriented presentation protocol: Protocol specification*

ISO/IEC 8824-1:1999, *Information technology – Abstract Syntax Notation One (ASN. 1): Specification of basic notation*
Amendment 1 (2000)
Amendment 2 (2000)

ISO/IEC 8825-1, *Information technology – ASN.1 encoding rules: Specification of Basic Encoding Rules (BER), Canonical Encoding Rules (CER) and Distinguished Encoding Rules (DER)*

ISO 9506-1:2003, *Industrial automation systems – Manufacturing Message Specification – Part 1: Service definition*

ISO 9506-2:2003, *Industrial automation systems – Manufacturing Message Specification – Part 2: Protocol specification*

IEEE 754:1985, *IEEE Standard for Binary Floating-Point Arithmetic*

IEEE 802.1Q:1998, *IEEE Standards for Local and Metropolitan Area Networks: Virtual Bridged Local Area Networks*

RFC 791, *Internet Protocol*; IETF, available at <<http://www.ietf.org>>

RFC 792, *Internet Control Message Protocol*; IETF, available at <<http://www.ietf.org>>

RFC 793, *Transmission Control Procedure*; IETF, available at <<http://www.ietf.org>>

RFC 826, *An Ethernet Address Resolution Protocol or Converting Network Protocol Addresses to 48.bit Ethernet Address for Transmission on Ethernet Hardware*; IETF, available at <<http://www.ietf.org>>

RFC 894, *A Standard for the Transmission of IP datagrams over Ethernet Networks*; IETF, available at <<http://www.ietf.org>>

RFC 919, *Broadcasting Internet Datagrams*; IETF, available at <<http://www.ietf.org>>

RFC 1006 *ISO transport services on top of TCP: Version 3; IETF, available at <<http://www.ietf.org>>*

RFC 1112, *Host Extensions for IP Multicasting; IETF, available at <<http://www.ietf.org>>*

3 Terms and definitions

For the purposes of this document, the definitions given in IEC 61850-2 apply.

4 Abbreviations

ACSI	Abstract Communication Service Interface
ASDU	Application Service Data Unit
ASN.1	Abstract Syntax Notation number One
APCI	Application Protocol Control Information
APDU	Application Protocol Data Unit
APPID	Application Identifier
AUI	Attachment Unit Interface
BER	ASN.1 Basic Encoding Rules
BS	Bitstring
c	Conditional support. The item shall be implemented if the stated condition exists
CFI	Canonical Format Identifier
CSMA/CD	Carrier Sense Multiple Access/Collision Detection
DF	Data Frame
DO	Data Object
ECT	Electronic Current Transformer
EVT	Electronic Voltage Transformer
F/S	Functional Standard
GOOSE	Generic Object Oriented Substation Event
GSSE	Generic Substation Status Event
i	Out-of-scope: The implementation of the item is not within the scope of this standard
ICD	IED Configuration Description
IED	Intelligent Electronic Device
LSDU	Link Layer Service Data Unit
m	Mandatory support. The item shall be implemented.
MAC	Media Access Control
MAU	Medium Attachment Unit
MMS	Manufacturing Message Specification (ISO 9506)
MSVCB	Multicast Sampled Value Control Block
MU	Merging Unit
o	Optional support. The implementor may decide to implement the item

PDU	Protocol Data Unit
PICS	Protocol Implementation Conformance Statement
SCSM	Specific Communication Services Mapping
r	readable
RIF	Routing Information Field (ISO/IEC 8802-5)
SV	Sampled Value
TCI	Tag Control Information
TPID	Tag Protocol Identifier
USVCB	Unicast Sampled Value Control Block
VID	VLAN Identifier
VLAN	Virtual Local Area Network
VMD	Virtual Manufacturing Device
w	Writeable
x	Excluded: The implementor shall not implement this item
XML	Extensible Markup Language

5 Communication stack

5.1 Overview of the protocol usage

The OSI reference model (ISO/IEC 7498-1) defines a model based upon the concept of layering of communication functions. The model includes 7 layers and specifies the functional requirements for each layer to achieve a robust communication system. The model does not specify the protocols to be used to achieve the functionality, nor does it restrict the solution to a single set of protocols.

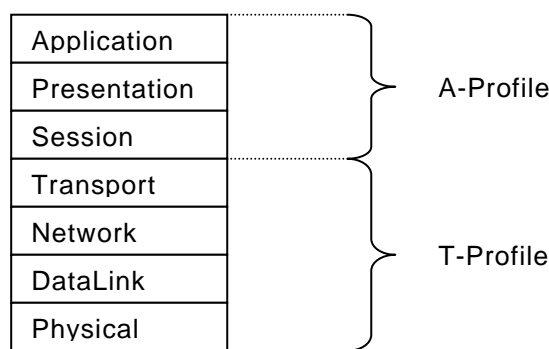

IEC 096/04

Figure 1 – OSI reference model and profiles

The use of ISO Application (A-Profile) and Transport (T-Profile) Profiles (see Figure 1) describes the various stack profiles. An ISO A-Profile is the set of specifications and agreements relating to the upper three (3) layers of the ISO OSI reference model (for example the application, presentation, and session layers). An ISO T-Profile is the set of specifications and agreements relating to the lower four (4) layers of the ISO OSI reference model (for example the transport, network, datalink and physical layers).

Two combinations of A-Profiles and T-Profiles are defined in order to support the transmission of sampled values including the access to the associated SV control block, as specified in IEC 61850-7-2. The two different combinations are used for:

- client/server services based on MMS in accordance to IEC 61850-8-1;
- SV services based on data link layer.

5.2 Client/server services and communication profiles

5.2.1 Client/server services

This client/server communication profile shall be used in addition to the SV communication profile according to 5.3 if an access to the sampled value control block via client is required. This profile shall be used for any implementation claiming conformance to this standard and declaring support for one of the following IEC 61850-7-2 services in Table 1.

Table 1 – Service requiring client/server communication profile

IEC 61850-7-2 model	IEC 61850-7-2 service
Server	GetServerDirectory
Association	Associate
	Abort
	Release
Logical device	GetLogicalDeviceDirectory
Logical node	GetLogicalNodeDirectory
	GetAllDataValues
Data	GetDataValues
	SetDataValues
	GetDataDirectory
	GetDataDefinition
Data set	GetDataSetValues
	SetDataSetValues
	CreateDataSet
	DeleteDataSet
SV class model	GetDataSetDirectory
	GetMSVCBValues
	SetMSVCBValues
	GetUSVCBValues
	SetUSVCBValues

5.2.2 A-Profile

Table 2 shows services and protocols of the A-Profile client/server.

Table 2 – Service and protocols for client/server communication A-Profile

OSI model layer	Specification			m/o
	Name	Service specification	Protocol specification	
Application	Manufacturing message specification	ISO 9506-1:2000	ISO 9506-2:2000	m
	Association control service element	ISO/IEC 8649:1996	ISO/IEC 8650-1:1996	m
Presentation	Connection oriented presentation	ISO/IEC 8822:1994	ISO/IEC 8823-1:1994	m
	Abstract syntax	ISO/IEC 8824-1:1999	ISO/IEC 8825-1	m
Session	Connection oriented session	ISO/IEC 8326:1996	ISO/IEC 8327-1:1997	m

There is only one T-Profile (TCP/IP) that may be used by the client/server A-Profile.

5.2.3 TCP/IP T-Profile

Table 3 shows services and protocols of the TCP/IP T-Profile client/server.

Table 3 – Service and Protocols for Peer TCP/IP T-Profile

OSI model layer	Specification			m/o
	Name	Service specification	Protocol specification	
Transport	ISO transport on top of TCP	RFC 1006		m
	Internet Control Message Protocol (ICMP)	RFC 792		m
	Transmission Control Protocol (TCP)	RFC 793		m
Network	Internet protocol	RFC 791		
	Converting network protocol address	RFC 826 (Address Resolution Protocol: ARP)		m
	Broadcasting internet datagrams	RFC 919		m
	Host extensions for IP multicasting	RFC 1112		m
DataLink	Standard for the transmission of IP datagrams over Ethernet networks	RFC 894		m
	Carrier Sense Multiple Access with Collision Detection (CSMA/CD)	ISO/IEC 8802-3:2001		m
Physical	Fibre optic transmission system 100Base-FX	ISO/IEC 8802-3:2001		c1
	Basic optical fibre connector NOTE This is the specification for the ST connector.	IEC 60874-10-1, IEC 60874-10-2 and IEC 60874-10-3		c1

c1 – Recommended, but future technology could be used.

5.3 SV service and communication profile

5.3.1 SV mapping overview

This SV communication profile shall be used for any implementation claiming conformance to this standard and declaring support for one of the following IEC 61850-7-2 services in Table 4.

Table 4 – Service requiring SV communication profile

Model	IEC 61850-7-2 service
Multicast sampled value class model	Multicast SV message
Unicast sampled value class model	Unicast SV message

5.3.2 A-Profile

Table 5 shows services and protocols of the A-Profile SV.

Table 5 – Service and protocols for SV communication A-Profile

OSI model layer	Specification			m/o
	Name	Service specification	Protocol specification	
Application	SV service			m
Presentation	Abstract syntax	ISO/IEC 8824-1:1999	ISO/IEC 8825	m
Session				

Presentation layer: see additional definitions in 8.5.

Application layer: see additional definitions in 8.5.

5.3.3 T-Profile

The T-Profile for SV Services is shown in Table 6.

Table 6 – SV T-Profile

OSI model layer	Specification			m/o
	Name	Service specification	Protocol specification	
Transport				
Network				
DataLink	Priority tagging/VLAN	IEEE 802.1Q		m
	Carrier Sense Multiple Access with Collision Detection (CSMA/CD)	ISO/IEC 8802-3:2001		m
Physical	Fibre optic transmission system 100Base-FX	ISO/IEC 8802-3:2001		c1
	Basic optical fibre connector NOTE This is the specification for the ST connector.	IEC 60874-10-1, IEC 60874-10-2 and IEC 60874-10-3		c1
c1 – Recommended, but future technology could be used.				

Physical layer: Specifications for the Medium Attachment Unit (MAU)

The optical fibre transmission system 100Base-FX according to ISO/IEC 8802-3 is recommended as indicated above because of requirements relating to the electromagnetic environment.

Link layer: Ethernet addresses

The destination ISO/IEC 8802-3 multicast/unicast address has to be configured for the transmission of sampled values. A unique ISO/IEC 8802-3 source address shall be used. Recommendations of multicast address range assignments are given in Annex C.

Link layer: Priority tagging/virtual LAN

Priority tagging according to IEEE 802.1Q is used to separate time critical and high priority bus traffic for protection relevant applications from low priority busload.

See Figure 2 for the structure of the tag header.

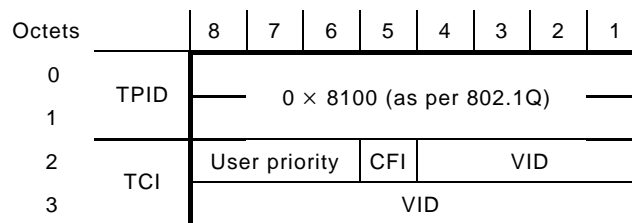

IEC 097/04

Key

TPID (Tag Protocol Identifier) Field:

Indicates the Ethernet Type assigned for 802.1Q Ethernet encoded frames. This value shall be 0x8100.

TCI (Tag Control Information) Fields:

User Priority: BS3; User priority value shall be set by configuration to separate sampled values from low priority busload. If the priority is not configured then the default values of Table 7 shall be used.

CFI (Canonical Format Indicator): BS1 [0]; A single bit flag value. For this standard the CGI bit value shall be reset (value = 0).

NOTE If set (value = 1), an Embedded Resource Identification Field (E-RIF) follows the Length/Type field in the ISO/IEC 8802-3 tagged frame.

VID: Virtual LAN support is optional. If this mechanism will be used, the VLAN Identifier (VID) shall be set by configuration, if it is not used, it shall be set to zero (0).

NOTE As IEEE 802.1Q allows implementation with a restricted set of priorities, the higher priority frames should have a priority of 4 to 7 and the lower priority should have a priority of 1 to 3. The value 1 is the priority of untagged frames thus 0 should be avoided as it may cause unpredictable delay due to normal traffic.

Additionally, since Sampled Values needs to have potentially its own bandwidth allocation, its configured VID will be different from GOOSE and GSE.

The default values for priority and VID shall be as defined in Table 7.

Figure 2 - Structure of the tag header

Table 7 – Default Virtual LAN IDs and priorities

Service	Default VID	Default priority
Sampled Values	0	4

The general ISO/IEC 8802-3 frame structure for sampled values can be found in Annex A.

Link layer: Ethertype and other header information

Etherypes based on ISO/IEC 8802-3 MAC – Sublayer are registered by the IEEE authority registration. GSE management, GOOSE and samples values shall be directly mapped to the reserved Ethertype(s) and the Ethertype PDU. The assigned values are found in Table 8.

Table 8 – Assigned Ethertype values

Use	Ethertype value (hexadecimal)	APPID type
IEC 61850-8-1 GOOSE	88-B8	0 0
IEC 61850-8-1 GSE Management	88-B9	0 0
IEC 61850-9-1 Sampled Values	88-BA	0 1
IEC 61850-9-2 Sampled Values	88-BA	0 1

The Ethertype PDU and APDU octets shall be as defined in annex A.

NOTE

APPID: application identifier. The APPID is used to select ISO/IEC 8802-3 frames containing sampled value messages and to distinguish the application association.

The value of APPID is the combination of the APPID type, defined as the two most significant bits of the value (as defined in Table 8), and the actual ID.

The reserved value range for sampled values is 0x4000 to 0x7FFF. If no APPID is configured, the default value shall be 0x4000. The default value is reserved to indicate lack of configuration. It is strongly recommended to have unique, source orientated SV APPID within a system, in order to enable a filter on link layer. The configuration of APPID should be enforced by the configuration system.

Length: Number of octets including the Ethertype PDU header starting at APPID, and the length of the APDU (Application Protocol Data Unit). Therefore, the value of Length shall be 8 + m, where m is the length of the APDU and m is less than 1492. Frames with inconsistent or invalid length field shall be discarded.

The Reserved1 and Reserved2 are reserved for future standardized applications and shall be set to 0 as default.

5.4 Restrictions

This mapping is restricted to the mapping of the ACSI model for the transmission of sampled values. The model applies to data sets. To get full benefit of IEC 61850, additional ACSI models need to be supported in accordance to IEC 61850-8-1. As an example, to enable the transmission of sampled value buffer, the associated control block attribute “SvEna” shall be written. However, if the client will read a list of available data sets or the contents of the data set, further models (for example logical device, logical node or data set) need to be supported.

This mapping specifies the transmission of data sets related to the sampled value model in addition to the universal data set specified in IEC 61850-9-1 of this standard. The data set status indication, which is also defined in IEC 61850-9-1, is not supported, because other communication methods are available for transmission of binary status indications.

Data sets for sampled values will be specified by using the XML language (except the universal data set which is defined in IEC 61850-9-1) on engineering level in accordance with IEC 61850-6 of this standard to ensure interoperability.

For the transmission of sampled value data sets, the ASN.1 Basic Encoding Rules (BER) will be used in combination with tags notation harmonised with the MMS grammar used in IEC 61850-8-1.

6 Mapping of IEC 61850-7-2 and IEC 61850-7-3 Data Attributes

The mapping of attributes and common data attributes to MMS are specified in IEC 61850-8-1.

For the transmission of sampled values the ASN.1, the Basic Encoding Rules (BER) and the common data classes defined in IEC 61850-7-3 of this standard apply.

7 Mapping of IEC 61850-7-2 classes and services

7.1 Classes of SV data sets

If a client/server association based on MMS is used in addition to the transmission of SV data sets, the definitions of IEC 61850-8-1 apply for the following classes:

- server class model;
- association model;
- logical device model;
- logical node model;
- data class model;
- data set class model.

7.2 Definition of SV data sets

For the transmission of sampled values, the data sets are defined in logical node "LLN0". All sampled value data sets specification are part of the IED Configuration Description (ICD), except the universal data set, which is fixed and defined in IEC 61850-9-1 of this standard.

NOTE It is assumed that the data sets used for the transmission of sampled values may include data objects from more than one logical node and are therefore allocated in LLN0.

8 Mapping of the model for the transmission of sampled values

8.1 Overview

To ensure interoperability, the data sets for sampled values are specified in XML according to the definition in clause 6 of this standard.

The sampled value class model provides reporting of sampled value data sets in an organised and time controlled way, so that transfer is very fast and time of transfer is kept constant. Sampled value control block for unicast and multicast defines the transmission characteristics of the data set they refer to. A detailed description is given in IEC 61850-7-2.

8.2 Mapping of the multicast sampled value control block class and services

8.2.1 Multicast sampled value control block definition

The sampled value control block, as defined in IEC 61850-7-2, shall be pre-defined by configuration or shall be mapped to an MMS Multicast Sampled Value Control Block (MSVCB) as defined in Table 9. All MSVCB components shall be of the functional constraint "MS".

Table 9 – MMS TypeDescription definition for MSVCB MMS structure

MMS component name	MMS TypeDescription	r/w	m/o	Condition	Comments
MsvCBNam	Identifier	r	m		MMS Identifier of the structure of the MsvCBName within the MMS object named: LLN0\$MV e.g. LLN0\$MS\$<MsvCBNam>
MsvCBRef	Visible-string	r	m		The value of this component shall contain the IEC Reference of the MsvCB. e.g. <MMSDomain>/LLN0\$MS\$<MsvCBNam>
SvEna	Boolean	r/w	m		TRUE = transmission of sampled value buffer is activated. FALSE = transmission of sampled value buffer is deactivated.
MsvID	Visible-string	r	m		System wide unique identification.
DatSet	Visible-string	r	m		The value of this component shall contain the IEC Reference of the DataSet conveyed by the MsvCB. This ObjectReference shall be limited to VMD or Domain scoped NamedVariableLists.
ConfRev	Integer	r	m		Count of configuration changes regard to MSVCB.
SmpRate	Integer	r	m		Amount of samples per period.
OptFlds	BitString				
refresh-time	Boolean	r	m		TRUE = SV buffer contains the attribute "RefrTm" FALSE = attribute "RefrTm" is not available in the SV buffer.
sample-synchronised Reserved	Boolean	r	m		TRUE = SV buffer contains the attribute "SmpSynch". FALSE = attribute "SmpSynch" is not available in the SV buffer. Reserved to ensure backward compatibility to IEC 61850-9-2 Edition 1.0 (sample synchronised).
sample-rate	Boolean	r	m		TRUE = SV buffer contains the attribute "SmpRate". FALSE = attribute "SmpRate" is not available in the SV buffer.
data-set	Boolean	r	m		TRUE = SV buffer contains the attribute "DatSet". FALSE = attribute "DatSet" is not available in the SV buffer.
security	Boolean	r	m		Mapping specific attribute. TRUE = SV buffer contains the attribute "Security". FALSE = attribute "Security" is not available in the SV buffer.
DstAddress	See Table 10		m		Mapping specific attribute.
noASDU	Integer	r	m		Mapping specific attribute. Number of ASDU concatenated into one APDU.

Table 10 - DstAddress structure

MMS component name	MMS TypeDescription	r/w	m/o	Condition	Comments
Addr	OCTET-STRING	r	m		<p>Length is 6 Octets and contains the value of the destination Media Access Control (MAC) address to which the SV message is to be sent.</p> <p>If DstAddress is member of a MSVCB, the address shall be an Ethernet Address that has the multicast bit set to TRUE.</p> <p>If DstAddress is member of a USVCB, the address shall be the Ethernet Address of the SV subscriber.</p> <p>See Annex C for multicast addressing recommendations</p>
PRIORITY	Unsigned8	r	m		Range of values shall be limited from 0 to 7.
VID	Unsigned16	r/w	m		Range of values shall be limited from 0 to 4095.
APPID	Unsigned16	r	m		As defined in 5.3.3.

8.2.2 MSV Services

See Table 11.

Table 11 – Mapping of multicast sampled value services

Services of MSVCB Class	Service
SendMSVMessage	Transmission of MSV messages is mapped directly on data link layer as defined in 8.4 and 8.5
GetMSVCBValue	Mapped to MMS read service
SetMSVCBValue	Mapped to MMS write service

8.3 Mapping of the unicast sampled value control block class and services

8.3.1 Unicast sampled value control block definition

The sampled value control block, as defined in IEC 61850-7-2, shall be pre-defined by configuration or shall be mapped to an MMS Unicast Sampled Value Control Block (USVCB) as defined in Table 12. All USVCB components shall be of the Functional Constraint “US”.

Table 12 – MMS TypeDescription definition for USVCB MMS Structure

MMS component name	MMS type description	r/w	m/o	Condition	Comments
UsvCBNam	Identifier	r	m		MMS Identifier of the structure of the UsvCBName within the MMS object named: LLN0\$MV e.g. LLN0\$US\$<UsvCBNam>
UsvCBRef	Visible-string	r	m		The value of this component shall contain the IEC Reference of the UsvCB. e.g. "<MMSDomain>/LLN0\$US\$<UsvCBNam>"
SvEna	Boolean	r/w	m		TRUE = transmission of sampled value buffer is activated. FALSE = transmission of sampled value buffer is deactivated.
Resv	Boolean	r/w	m		TRUE = USVCB is exclusively reserved for the client that has set this value to TRUE.
UsvID	Visible-string	r	m		System-wide unique identification.
DatSet	Visible-string	r	m		The value of this component shall contain the IEC Reference of the DataSet conveyed by the UsvCB. This ObjectReference shall be limited to VMD or Domain scoped NamedVariableLists.
ConfRev	Integer	r	m		Count of configuration changes regard to USVCB.
SmpRate	Integer	r	m		Amount of samples per nominal periods.
OptFlds	BitString				
refresh-time	Boolean	r	m		TRUE = SV buffer contains the attribute "RefrTm" FALSE = attribute "RefrTm" is not available in the SV buffer.
sample-synchronised Reserved	Boolean	r	m		TRUE = SV buffer contains the attribute "SmpSynch" FALSE = attribute "SmpSynch" is not available in the SV buffer. Reserved to ensure backward compatibility to IEC 61850-9-2 Edition 1.0 (sample synchronised).

	sample-rate	Boolean	r	m	TRUE = SV buffer contains the attribute "SmpRate". FALSE = attribute "SmpRate" is not available in the SV buffer.
	data-set	Boolean	r	m	TRUE = SV buffer contains the attribute "DatSet". FALSE = attribute "DatSet" is not available in the SV buffer.
	security	Boolean	r	m	Mapping specific attribute. TRUE = SV buffer contains the attribute "Security". FALSE = attribute "Security" is not available in the SV buffer.
	DstAddress	See Table 10		m	Mapping specific attribute.
	noASDU	Integer	r	m	Mapping specific attribute. Number of ASDU concatenated into one APDU.

8.3.2 USV Services

See Table 13.

Table 13 – Mapping of unicast sampled value services

Services of USVCB class	Service
SendUSVMessage	Transmission of USV messages is mapped directly on data link layer as defined in 8.4 and 8.5
GetUSVCBValue	Mapped to MMS read service
SetUSVCBValue	Mapped to MMS write service

8.4 Mapping of the update of the sampled value buffer

As specified in IEC 61850-7-2, the communication system is responsible to update the buffer of the subscriber.

The update is directly mapped to an ethertype reserved for IEC 61850 applications based on ISO/IEC 8802-3 MAC – Sublayer.

The communication stack used does not provide the following functionality:

- Initiating and checking the update of the sampled value buffer over the communication link. Optionally concatenating the update of more than one buffer into the same link layer frame. This is an application layer functionality.
- Encoding the abstract data types. This is a presentation layer functionality.
- Concatenating the update of more than one transmission buffer into the same link layer frame as a transport layer functionality is not supported. The opposite, to segment the update of one buffer to several link layer frames is not considered, since the maximum frame length of the link layer protocols is sufficient.
- Translating the logical address of the subscriber in a physical MAC address.

Therefore, the additional definitions of 8.5 apply.

8.5 Additional definitions for the transmission of sampled values

Application layer functionality

The mapping provides the capability to concatenate more than one ASDU into one APDU before the APDU is posted into the transmission buffer. The numbers of ASDUs which will be concatenated into one APDU are configurable and related to the sample rate. The concatenation of ASDUs is not dynamically changeable in order to reduce the implementation complexity. When concatenating several ASDUs into one frame, the ASDU with the oldest samples is the first one in the frame.

Details are shown in Figure 3.

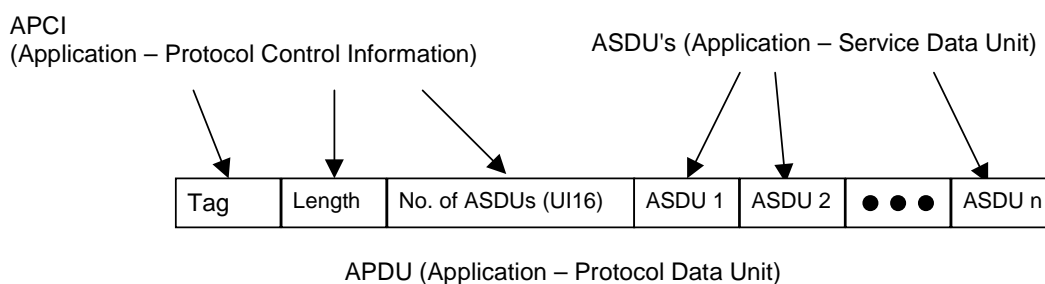

Figure 3 – Concatenation of several ASDU's into one frame

ASN.1 grammar in relation with the Basic Encoding Rules (BER) is used to encode the sampled value messages for transmission on ISO/IEC 8802-3. To guarantee compatibility to IEC 61850-9-1, the first ASN.1 tag (9-1-Pdu) of the sampled value PDU are reserved for the universal data set. The ASN.1 grammar for the sampled value messages are defined as follows to ensure data consistency to IEC 61850-9-1 and in combination with further sampled value messages as described in this SCSM.

Presentation layer functionality

For the transmission, the sampled value buffer is encoded as specified in the Table 14:

Table 14 – Encoding for the transmission of the sampled value buffer

```
IEC61850 DEFINITIONS ::= BEGIN
IMPORTS Data FROM ISO-IEC-9506-2
IEC 61850-9-2 Specific Protocol ::= CHOICE {
  9-1-Pdu    [0] IMPLICIT OCTET STRING, -- Reserved for 9-1 APDU
  savPdu     [APPLICATION 0] IMPLICIT SavPdu,
```

Abstract Buffer Format according to IEC 61850-7-2		Coding in IEC 61850-9-2	Comments
Attribute name	Attribute type	ASN.1 Basic Encoding Rules (BER) SavPdu ::= SEQUENCE {	
		noASDU [0] IMPLICIT INTEGER (1..65535),	Mapping specific attribute. Number of ASDUs, which will be concatenated into one APDU.
Security		security [1] ANY OPTIONAL,	Mapping specific attribute. Reserved for future definition (e.g. digital signature).
		asdu [2] IMPLICIT SEQUENCE OF ASDU }	1 to <i>n</i> number of ASDUs as specified before.
		ASDU ::= SEQUENCE {	
MsvID or UsvID	VISIBLE STRING	svID [0] IMPLICIT VisibleString,	Should be a system-wide unique identification.
DatSet	ObjectReference	datset [1] IMPLICIT VisibleString OPTIONAL,	Value from the MSVCB or USVCB
SmpCnt	INT16U	smpCnt [2] IMPLICIT OCTET STRING (SIZE(2)),	Will be incremented each time a new sampling value is taken. The counter shall be set to zero if the sampling is synchronised by clock signal (SmpSynch = TRUE) and the synchronising signal occurs. See NOTE 2. The OCTET STRING is interpreted as INT16U as defined in Table 15
ConfRev	INT32U	confRev [3] IMPLICIT OCTET STRING (SIZE(4)),	Value from the MSVCB or USVCB. The OCTET STRING is interpreted as INT32U as defined in Table 15
RefrTm	EntryTime	refrTm [4] IMPLICIT UtcTime OPTIONAL,	RefrTm contains the refresh time of the SV buffer.
SmpSynch	INT8U	smpSynch [5] IMPLICIT OCTET STRING (SIZE(1)),	2 = SV are synchronised by a global area clock signal. 1 = SV are synchronised by a local area clock signal. 0 = SV are not synchronised by an external clock signal.
SmpRate	INT16U	smpRate [6] IMPLICIT OCTET STRING (SIZE(2)) OPTIONAL,	Value from the MSVCB or USVCB. The OCTET STRING is interpreted as INT16U as defined in Table 15
Sample [1..n]	Type depends on the CDC defined in IEC 61850-7-3.	sample [7] IMPLICIT OCTET STRING (SIZE(n)) }	List of data values related to the data set definition. See NOTE 1.
NOTE 1 For the encoding of the Data, the rules for the encoding of the basic data types shall apply as defined in Table 14. The SIZE(n) is the cumulated size of all the data conveyed as defined in the DataSet.			
NOTE 2 When sync pulses are used to synchronise merging units, the counter shall be set to zero with every sync pulse. The value 0 shall be given to the data set where the sampling of the primary current coincides with the sync pulse.			
NOTE 3 The usage of the OptFlds attribute according to IEC 61850-7-2 is not necessary, because the relating attributes RefrTm, SmpSynch, security, SmpRate and DataSet will be signed as optional via the ASN.1 attribute directly.			

... }

END

For the tag definition of basic data types, see 8.6.

8.6 Definitions for basic data types

Presentation layer functionality

Table 15 shows the encoding for the basic data types used for the Data values referenced by the data set members.

Table 15 – Encoding for the basic data types

Data types according to IEC 61850-7-2	Encoding in data set	Comments
BOOLEAN	8 Bit set to 0 FALSE; anything else = TRUE	
INT8	8 Bit Big Endian	signed
INT16	16 Bit Big Endian	signed
INT32	32 Bit Big Endian	signed
INT128	128 Bit Big Endian	signed
INT8U	8 Bit Big Endian	unsigned
INT16U	16 Bit Big Endian	unsigned
INT24U	24 Bit Big Endian	unsigned
INT32U	32 Bit Big Endian	unsigned
FLOAT32	32 Bit IEEE Floating Point (IEEE 754)	
FLOAT64	64 Bit IEEE Floating Point (IEEE 754)	
ENUMERATED	32 Bit Big Endian	
CODED ENUM	32 Bit Big Endian	
OCTET STRING	20 Bytes ASCII Text, Null terminated	
VISIBLE STRING	35 Bytes ASCII Text, Null terminated	
UNICODE STRING	20 Bytes ASCII Text, Null terminated	
ObjectName	20 Bytes ASCII Text, Null terminated	
ObjectReference	20 Bytes ASCII Text, Null terminated	
TimeStamp	64 Bit Timestamp as defined in IEC 61850-8-1	
EntryTime	48 Bit Timestamp as defined in IEC 61850-8-1	
Data types according to IEC 61850-8-1	Encoding in data set	Comments
BITSTRING	32 Bit Big Endian	

9 Conformance

9.1 Notation

For the following clause, see the abbreviations given in Clause 4.

9.2 PICS

9.2.1 Profile conformance

Table 16 and Table 17 define the basic conformance statement.

Table 16 – PICS for A-Profile support

		Client		Server		Value/comment
		F/S		F/S		
A1	Client/Server A-Profile	c1		c1		Refer to 5.2
A2	SV A-Profile	c2		c2		Refer to 5.3
<p>c1 – Shall be 'm' if support for any service specified in Table 1 are declared within the ACSI basic conformance statement.</p> <p>c2 – Shall be 'm' if support for any service specified in Table 4 are declared within the ACSI basic conformance statement.</p>						

Table 17 – PICS for T-Profile support

		Client		Server		Value/comment
		F/S		F/S		
T1	TCP/IP T-Profile	c1		c1		
T2	SV T-Profile	c2		c2		
<p>c1 – Shall be 'm' if support for A1 is declared. Otherwise, shall be 'i'</p> <p>c2 – Shall be 'm' if support for A2 is declared. Otherwise, shall be 'i'.</p>						

9.2.2 SV Services

This clause describes the Protocol Implementation Conformance Statement for sampled values services based on the IEC 61850-7-2 basic conformance statement. See Table 18.

Table 18 – SV conformance statement

Services	Client/ subscriber	Server/ publisher	Value/comment
Multicast			
SendMSVMessage	c1	c1	
GetMSVCBValues	c2	c2	
SetMSVCBValues	c3	c3	
Unicast			
SendUSVMessage	c1	c1	
GetUSVCBValues	c2	c2	
SetUSVCBValues	c3	c3	
<p>c1 – Shall declare 'm' for at least one (MSV or USV) as declared within ACSI basic conformance statement.</p> <p>c2 – Shall be 'o' as declared within ACSI basic conformance statement. See IEC 61850-8-1, Table 95 Read Conformance Statement.</p> <p>c3 – Shall be 'o' as declared within ACSI basic conformance statement. See IEC 61850-8-1, Table 96 Write Conformance Statement.</p>			

10 Substation Configuration language (SCL)

Conforming implementations shall support the Substation Configuration Language as defined in IEC 61850-6 for exchange between engineering tools.

SCSM specific address element definitions

This Clause defines the xs:string types that are allowed for the SV addressing as type parameters of the P element of the Address element. The values and character restrictions are defined in Table 19.

Table 19 – Definitions for SV SCL

P-type designation	Description	m/o	Restrictions/comments
MAC-Address	Media Access Address value	m	Shall be 6 groups of 2 visible characters separated by hyphens(-). Characters shall be limited to 0-9 and A-F.
APPID	Application Identifier	o	Shall be 4 characters. Characters shall be limited to 0 to 9 and A to F.
VLAN-PRIORITY	VLAN User Priority	c1	Shall be a single character. Characters shall be limited to 0 to 7.
VLAN-ID	VLAN ID	o	Shall be 3 characters. Characters shall be limited to 0 to 9 and A to F.
c1 – Shall only be present if VLAN is also present.			

A.2 ASN.1 Basic Encoding Rules (BER)

ASN.1 Basic encoding rules (as specified in ISO/IEC 8825-1) will be used for encoding and decoding of Sampled Values. The main encoding principles are shown as an overview.

The BER transfer syntax has the format of a triplet TLV (Type, Length, Value) or (Tag, Length, Value) as shown in Figure A.2.

All fields (T, L, V) are series of octets. The value V can be a triplet TLV itself, if it is constructed.

The transfer syntax is octet-based and “big endian”-oriented. The length field L defines the length of each TLV triplet.

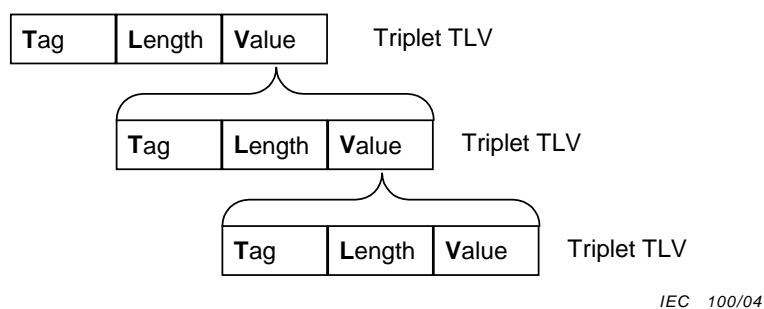
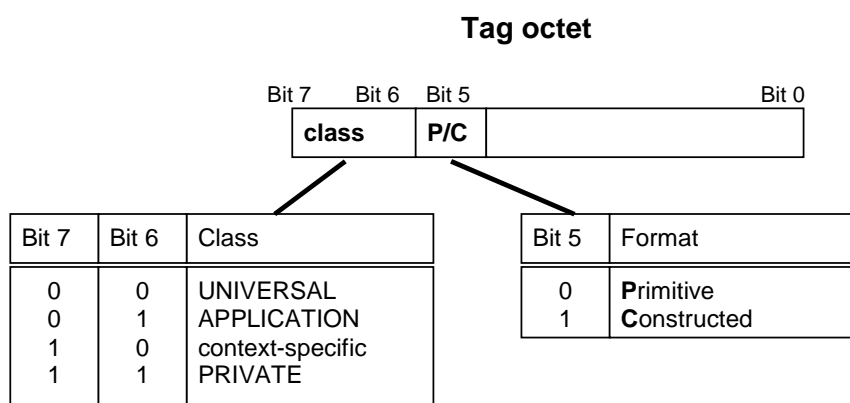

Figure A.2 - Basic encoding rules format

The tag octets correspond to the encoding of the tag of the value type. Figure A.3 shows the two formats of the tag octets T



IEC 101/04

Figure A.3 - Format of the tag octets

Annex B (informative)

Process bus architectures

The communication bus can be arranged in several different ways, depending on data flow requirements, reliability requirements or practicalities during installation.

Figure B.1 shows four alternative solutions of the process bus architectures.

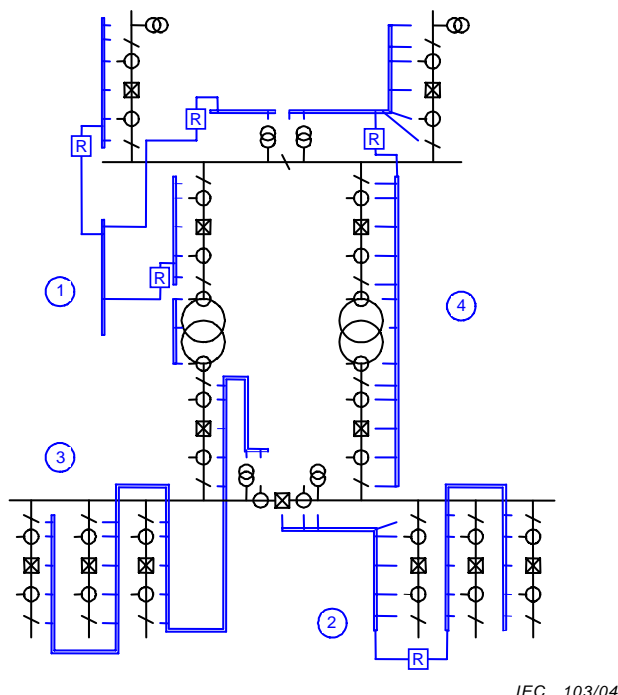

Figure B.1 - Alternative process bus architectures

Alternative 1 indicates a communication bus structure where each bay (installation unit) has its own process bus segment. To allow for protection and control equipment that requires data from more than one segment, a separate station-wide communication bus is installed, with switches or routers to each bay segment to transmit the required data streams.

Alternative 2 indicates a similar structure but each bay segment covers more than one bay. Data streams required by more than one segment are transferred by switches or routers. The example shows data from the busbar voltage transformer being used by directional earth-fault relays on all bays.

Alternative 3 indicates a single station-wide communications bus, to which all devices are connected. This requires a very high data rate on the bus, but eliminates the need for routers.

Alternative 4 indicates a function oriented bus structure. In this case the bus segments are set up to correspond to protection zones. Although routers are required, the segments can be arranged to minimize the data to be transferred between segments.

The process bus has to be considered as a substation entity with defined interfaces. The process bus may therefore have properties such as reliability and performance that are reflected on the interface characteristics. The properties will be included in the substation design/integration, for example in reliability and performance calculations, as any other entity. The process bus entity may, and will, comprise several parts that vary by vendor and implementation.

As a consequence of this model, the process bus may be a single 'entity' or divided into several 'entities' that may be interconnected or chained. The characteristics of the process bus 'entity' will depend on the realization (one or many process busses, etc.).

Annex C (informative)

Multicast address selection

In order to increase the overall performance of multicast message reception (for example GOOSE, GSSE, and Sampled Values), it is preferable to have the Media Access Controller (MAC) hardware perform the filtering. The hash algorithms in the various integrated circuits do vary. It is recommended, as a system integrator, to evaluate the impact of these algorithms when assigning destination multicast addresses.

Vendors of IEC 61850-8-1 or IEC 61850-9-2 implementations that send these types of messages should provide recommendations of addressing based upon the MAC IC's hash algorithms. One such recommendation might appear as follows:

The multicast addresses (octet string of size 6) used within this standard will have the structure:

- The first three octets are assigned by IEEE with 01-0C-CD.
- The fourth octet will be 01 for GOOSE, 02 for GSSE, and 04 for multicast sampled values.
- The last two octets will be used as individual addresses assigned by range defined in Table C.1.

Table C.1 – Recommended multicast addressing example

Service	Recommended address range assignments	
	Starting address (hexadecimal)	Ending address (hexadecimal)
GOOSE	01-0C-CD-01-00-00	01-0C-CD-01-01-FF
GSSE	01-0C-CD-02-00-00	01-0C-CD-02-01-FF
Multicast sampled values	01-0C-CD-04-00-00	01-0C-CD-04-01-FF